



# Single Lever Vessel Glass Waterfall Bathroom Faucet

KGW-1700

## **Congratulations on the purchase of your new Kraus® plumbing fixture!**

Please keep the box and packaging materials until your product is completely installed. If you have any questions, require technical assistance or have any problems with your product:



**DO NOT RETURN TO STORE**

**Please contact our Customer Service Team  
1-800-775-0703 / [customerservice@kraususa.com](mailto:customerservice@kraususa.com)**

Have the model number available and retain a copy of your receipt with purchase date for reference.

If for any reason this product does not meet your expectations, please be sure to repack this product in the original box and packaging material to avoid damage during transit.



### Prior to Installation:

- Make sure you have all necessary parts by checking the diagram and parts list. If any part is missing or damaged, please contact Kraus<sup>®</sup> Customer Service at 800-775-0703 for a replacement.
- Read all instructions and safety warnings and ensure you have all tools, parts, and equipment necessary for a safe installation.
- Turn off the hot and cold water supply at the angle stops and turn on the old faucet to release any built up pressure. Remove existing faucet. Clean sink or countertop to remove any debris, plumber's putty, or silicone.
- Flush angle stops to release any debris prior to installation.
- Pre-drilled hole size requirement: 1 3/8" (min)
- Max countertop thickness: 1 3/8"

For technical assistance or replacement parts, please contact Kraus Customer Service and one of our representatives will be happy to help:  
Toll-Free: 800-775-0703 or [Customerservice@kraususa.com](mailto:Customerservice@kraususa.com)

### Tools Required

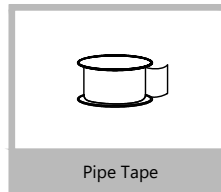
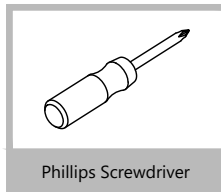
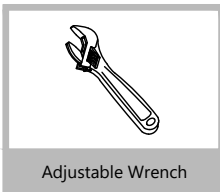

## Diagram and Parts List

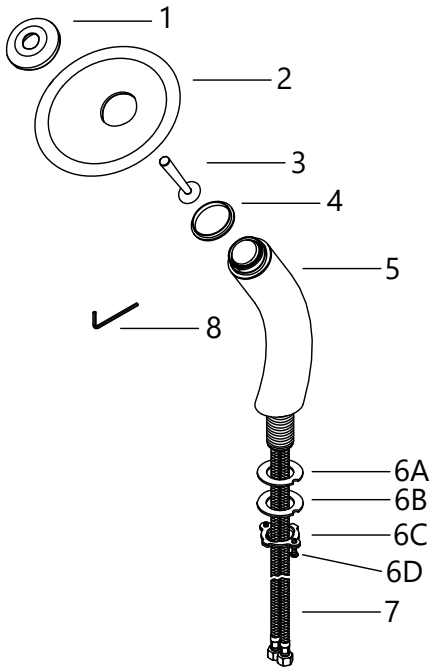

1. Decorative Ring
2. Glass Disc
3. Lever
4. Seal for Glass Disc
5. Faucet Body
6. Mounting Hardware
  - A. Rubber Washer
  - B. Metal Washer
  - C. Mounting Nuts
  - D. Mounting Screws
7. Hot & Cold Waterlines
8. Hex Wrench

# Faucet Dimensions

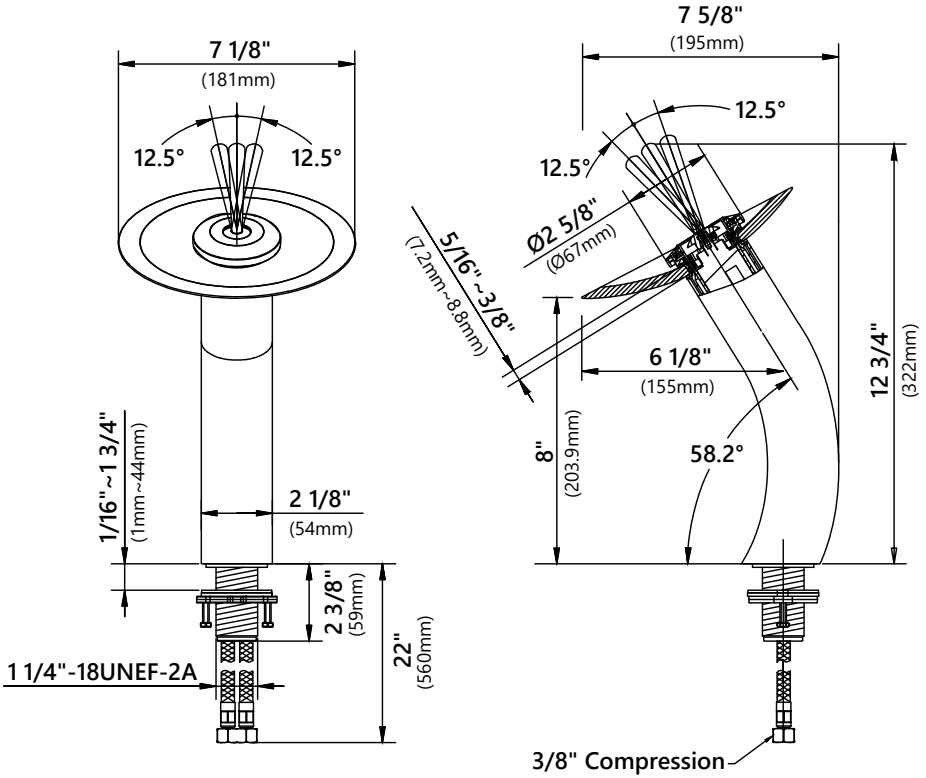

## Installer Tip:

Shut off main water supply before installing new faucet.

## Rough-In Dimensions

PLEASE NOTE: Glass Vessel Sinks are handcrafted. As a result slight variations in size and shape are to be expected. We recommend not cutting any surfaces based on the sizes and dimensions provided until the product is received. KRAUS shall not be held accountable for any custom installation issues. Under no circumstances will KRAUS be held liable for the cost of the repair or replacement of installation materials including but NOT limited to: marble, stone, granite countertops, tiles, etc. Deviations from recommended installations, misuse, neglect, abuse, modifications or alterations may void your warranty. We advise that you comply with Local Building Codes as they may vary from state to state.

### Glass Vessel Sink and Waterfall Faucet Combo

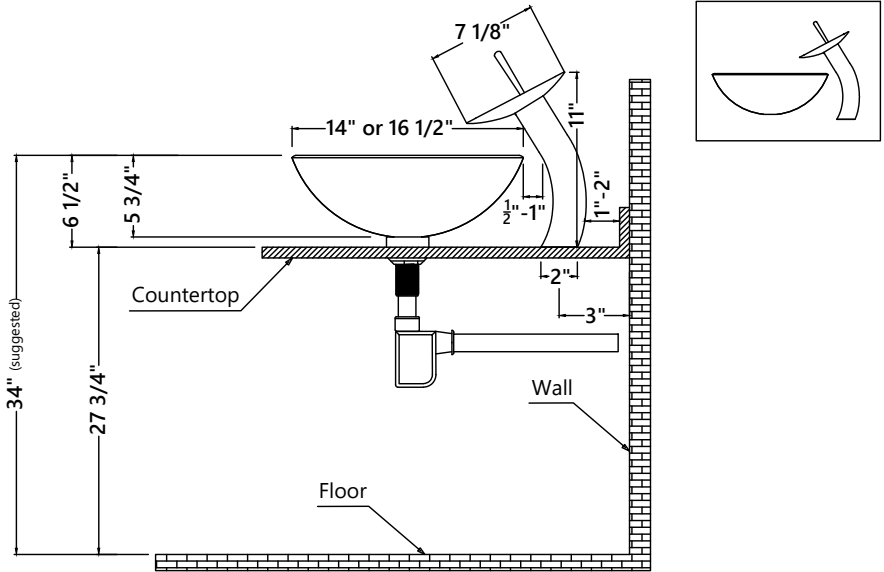

### Suggested Dimensions for 14\"/>

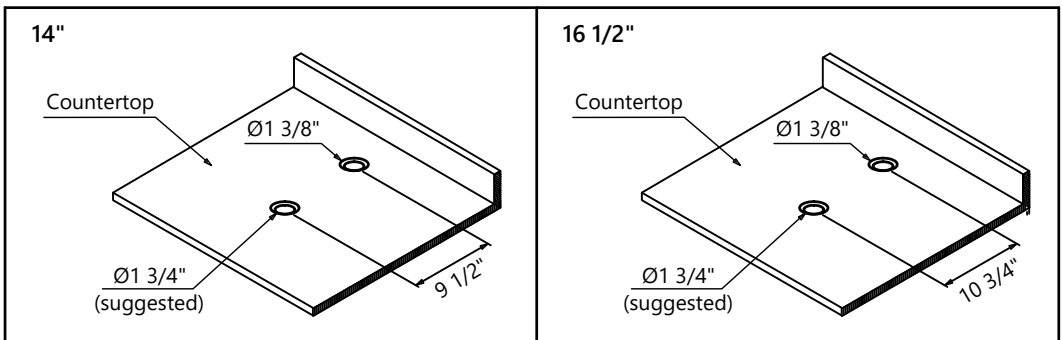

## Step 1. Remove mounting hardware

---

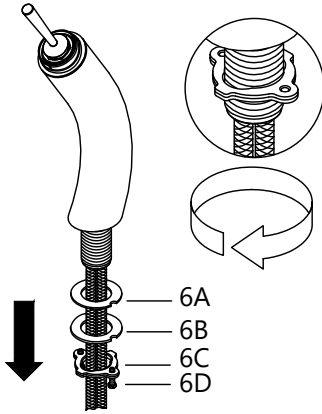

Remove mounting hardware (6A, B, C, & D) from the mounting pipe.

## Step 2. Remove decorative ring

---

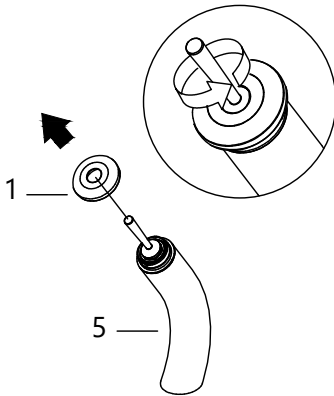

Remove decorative ring (1) from faucet body (5).

### Step 3. Install glass disc

---

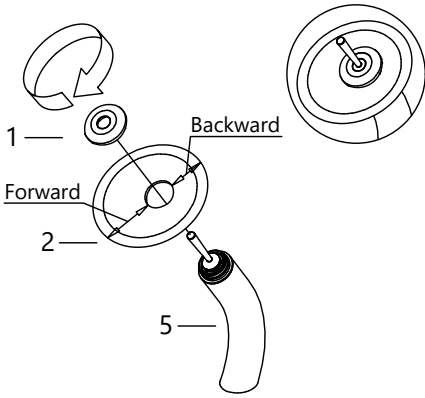

Install glass disc (2) on faucet body (5). Secure it using decorative ring (1).

**NOTE: Hand-tighten only  
(decorative ring)**

### Step 4. Install faucet

---

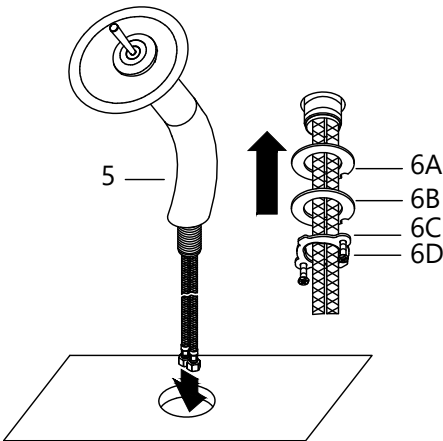

Insert faucet body (1) into the hole on the countertop. Attach rubber washer (6A), metal washer (6B), mounting nut (6C), and mounting screws (6D) from underneath the sink.



## Step 5. Secure mounting hardware

---

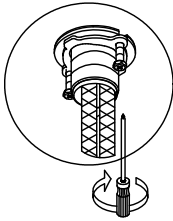
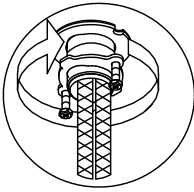

Adjust direction of faucet body (5). Tighten mounting nut (6C) until snug. Tighten mounting screws (6D) to nut with a Phillips head screwdriver until snug.

## Step 6. Connect waterlines to main valve

---

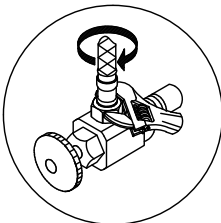
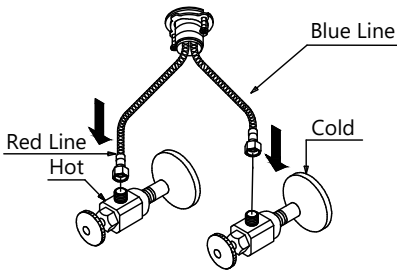

Connect hot and cold waterlines (7) to the angle stops. Tighten with a wrench until snug. Turn on hot and cold angle stops and check for leaks.

**NOTE:** Make sure O-rings are installed on both ends of the hot & cold waterlines

## Step 7.

---

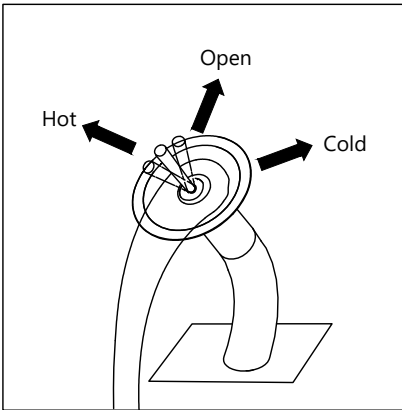

Turn water on for a minute to ensure proper water flow.

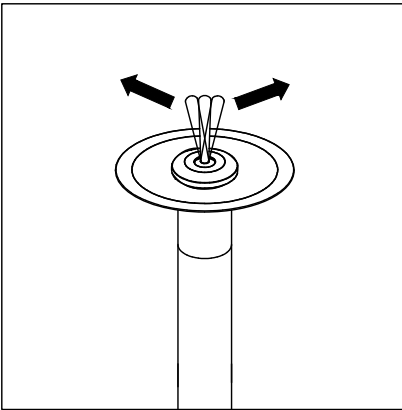

# Replacement Parts

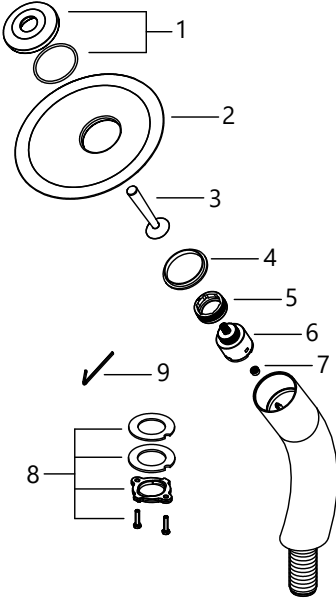

Replacement Parts List	Finish/Color	Part #
1. Decorative Ring & O-ring	CH, SN, ORB*	KP07059
2. Glass Disc		N/A
3. Lever	CH, SN, ORB*	KP07057
4. Seal for Glass Disc		KP07061
5. Locking Nut		KP07063
6. Cartridge		KP07062
7. Flow Restrictor		KP07064
8. Mounting Hardware		KP07066
9. Hex Wrench 2mm		KP07067

\*Denotes faucet component color options:  
 CH - Chrome  
 SN - Satin Nickel  
 ORB - Oil Rubbed Bronze

## Trouble-Shooting

If you have followed the instructions carefully and your faucet still does not work properly, take the following corrective steps:

PROBLEM	CAUSE	ACTION
Leakage under the faucet handle	Locking nut has come loose.	Unscrew the decorative ring (by hand) and remove the glass disc. Loosen set screw with a hex wrench located underneath lever and remove lever. Tighten locking nut with a reversible wrench.
Water does not shut off completely	Cartridge may be defective.	Unscrew decorative ring (by hand) and remove glass disc. Loosen set screw with a hex wrench located underneath lever and remove lever. Unscrew locking nut with a reversible wrench. Remove ceramic disc cartridge. Check for cracks.
Drain is leaking	Washers may be compromised or installed incorrectly.	Check washers to make sure they are installed correctly and not cracked.

## Care & Maintenance

\* To keep the product clean & shining, follow the steps below:

1. Rinse with clean water & dry with a soft cloth
2. Do not clean with soaps, acid, polish, abrasives or harsh cleaners
3. Do not use cloth with a coarse surface
4. Unscrew the aerator and clean when necessary



\* This installation manual is subject to change without further notice.

## Codes/Standards Applicable:



NSF / ANSI 61



ASME A112.18.1  
2.2GPM 8.3L/min maximum

### Faucet - Lifetime Limited Warranty

Kraus USA Plumbing, LLC ("Kraus") extends this warranty to the original purchaser for personal household use of the Faucet when purchased from an authorized Kraus dealer and in the location of original installation. This warranty is non-transferable.

Kraus warrants the structure and finish of the Faucet to be free from defects in material and workmanship under normal usage for as long as the original purchaser resides in the residence in which the Faucet was first installed.

Kraus warrants the Faucet's sprayhead assembly (including the engine, aerators, structure, restrictors, back flow preventers, sprayer hoses, braided supply line hoses which encompasses nylon, silicon and stainless steel) of the product to be free from defects in material and workmanship under normal usage for a period of one (1) year from the date of purchase.

Kraus warrants the Faucet's cartridge to be free from defects in material and workmanship under normal usage for a period of five (5) years from the date of purchase.

Any product reported to the authorized dealer or to Kraus as being defective within the warranty period will be repaired or replaced with a product of equal value at the option of Kraus.

### Commercial Warranty

Kraus USA Plumbing, LLC ("Kraus") warrants its Products for a period of one (1) year to commercial purchasers of Products used in industrial, commercial and business applications.

### Care and Cleaning Instructions

Certain cleaning products may cause damage to a Product's finish and use of the following on the Product will void this warranty:

- Abrasive cleaners such as powders, bleach, ammonia, alcohol or chlorine
- Abrasive pads, steel wool or wire brushes

### What is Not Covered

This warranty does not cover Products that were discontinued when purchased or display Products, whether such Products were purchased at discount outlets, unauthorized dealers, and/or sold on clearance. This warranty does not cover any free gifts included with purchase.

This warranty does not cover damage resulting from neglect, misuse (including use for an unintended application), abuse, carelessness, accident, hard water or mineral deposits, exposure to corrosive materials, improper maintenance, alteration of the Product, or failure to follow care, cleaning or installation instructions enclosed with your Product. Kraus recommends that all Kraus Products be installed by a fully licensed and insured trade professional with experience in the installation of bathroom and/or kitchen manufactured goods.

### How to Make a Warranty Claim

If you are a **consumer purchaser**, please contact a Kraus® Customer Service Representative at:  
Kraus USA Plumbing, LLC  
12 Harbor Park Drive  
Port Washington, NY 11050  
Toll-free 800-775-0703  
Customerservice@kraususa.com

If you are a **plumbing contractor or trade professional**, please contact a Kraus Pro Representative at:  
Kraus USA Plumbing, LLC  
12 Harbor Park Drive  
Port Washington, NY 11050  
516-801-8955  
Proservice@kraususa.com

If you are an **authorized partner**, please contact a Partner Support Representative at:  
Kraus USA Plumbing, LLC  
12 Harbor Park Drive  
Port Washington, NY 11050  
516-801-8954  
Partnersupport@kraususa.com

In requesting warranty service, please be ready to provide your proof of purchase and a description of the problem. Shipping charges will be covered for the first (1) year of the warranted replacement part or product (HI, AK, and Puerto Rico shipping charges may apply). International shipping fees are not included.

### Limitation on Duration of Implied Warranties

Please note that some states/provinces (including Quebec) do not allow limitations on how long an implied warranty lasts, so the below limitations may not apply to you. TO THE MAXIMUM EXTENT PERMITTED BY APPLICABLE LAW, ANY IMPLIED WARRANTY, INCLUDING THE IMPLIED WARRANTIES OF MERCHANTABILITY AND OF FITNESS FOR A PARTICULAR PURPOSE, IS LIMITED TO THE STATUTORY PERIOD OR THE DURATION OF THIS WARRANTY, WHICHEVER IS SHORTER.

### Limitation of Special, Incidental or Consequential Damages

Please note that some states/provinces (including Quebec) do not allow the exclusion or limitation of special, incidental or consequential damages, so the below limitations and exclusions may not apply to you. TO THE MAXIMUM EXTENT PERMITTED BY APPLICABLE LAW, THIS WARRANTY DOES NOT COVER, AND KRAUS USA PLUMBING, LLC SHALL NOT BE LIABLE FOR, ANY SPECIAL, INCIDENTAL OR CONSEQUENTIAL DAMAGES (INCLUDING LABOR CHARGES TO REPAIR, REPLACE, INSTALL OR REMOVE THIS PRODUCT), WHETHER ARISING OUT OF BREACH OF ANY EXPRESS OR IMPLIED WARRANTY, BREACH OF CONTRACT, TORT, OR OTHERWISE.

This warranty gives you specific legal rights, and you may also have other rights which vary from state/province to state/province.

**Download the Kraus Care & Maintenance Guide at:**  
<http://www.kraususa.com/maintenance>

# IMPORTANT

## Register Your Kraus® Product

**Activate** Your Warranty

**Access** Premium Customer Support

**Get** Product Information

**REGISTER TODAY**

<http://www.kraususa.com/registration>



**Kräus®**  
www.kraususa.com